



BRIGHTWOOD®

100% MADE IN ITALY

04-25 Introduction \ Introduzione

26-63 2023 Collection \ Collezione

46-51 TESEO

52-55 IPPOLITA

56-61 BEATRICE

62-63 ENEA

66-74 Finishings \ Finiture

Designed by Nature,
Discovered in Italy

Brightwood® is the first brand synonymous
with a design brought to the world
by a force that is more dynamic and creative
than any designer who has ever walked the planet:

MOTHER NATURE.

For the first time, and after many years
of avid research driven by curiosity, love and a passion for wood,
Brightwood® discovers and reveals the beauty
that Nature conceals in every type of wood.

Nature and technology: stark contrasts, paradoxical
and apparently irreconcilable concepts,
produce a magical effect with Brightwood®.
The beauty of wood is nurtured, revealed, celebrated, enhanced
and amplified by technology in a sort
of connection between Humans and Nature,
expressed in the form of a luminous dialogue
using technology and natural LED lighting.

Nature Technology



Disegnato dalla Natura,
Scoperto in Italia

Brightwood® è il primo marchio sinonimo di un design consegnato al mondo da una forza più brillante di qualunque altro designer che abbia mai messo piede sul nostro pianeta:

MADRE NATURA.

Curiosità, amore e passione per il legno hanno accompagnato Brightwood® a scoprire e svelare per la prima volta e dopo anni di appassionata ricerca, la bellezza fin qui celata dalla Natura in ogni essenza lignea.

Natura e tecnologia: contrasti estremi, concetti opposti ed all'apparenza inconciliabili, creano con Brightwood® un effetto magico. La bellezza del legno è valorizzata, svelata, celebrata, esaltata ed amplificata dalla tecnica, in una sorta di connessione tra Uomo e Natura espressa sotto forma di dialogo luminoso che si avvale della tecnologia e della luce LED.

Wood is an ancestral expression of the flow of life, the heartbeat of the ages, the protective skin of our planet; each type of wood is particular – asymmetrical, rough, irregular, unique and extraordinary.

It is purity in its most perfect form: design, colors, veining and textures that tell the history of Nature. As simple servants, we have the privilege of being able to look after it, while also exalting its intrinsic beauty invisible to the naked eye.

Il legno è una espressione ancestrale del flusso della vita, il battito del cuore delle epoche, la pelle del nostro pianeta; ogni essenza lignea con le sue peculiarità, è asimmetrica, grezza, irregolare, unica e straordinaria.

È la purezza nella sua forma più perfetta: design, colori, venature e trame che ci consegna la storia della Natura.

Noi, semplici servitori, abbiamo il privilegio di potercene prendere cura esaltandone anche l'intrinseca bellezza non visibile ad occhio nudo.

BRIGHTWOOD®



With Brightwood®, the different woods become part of a skillful play of lights and shadows, reflections and colors, providing a multi-sensory experience between dream and reality; the wood is processed, shaped and modified by skilled craftspeople, giving life to unique works, each time characterized by a variable, unexpected, sensory and relaxing energy that is both striking and communicative, and where the meeting of light and wood reveals the material's hidden soul and its three-dimensional and secret nature.

Unlike inanimate matter, the character of wood is expressed through its imperfections, which in turn become strengths that are forever unique and diverse, differing precisely because of wood's natural, dynamic and vibrant vitality. Brightwood® enhances the silent materic symphony of wood, each time telling an ancient but forever new story made of colors and shades, exalting the mysterious, unique and unexpected three-dimensional charm of all types of wood.

Con Brightwood® i legni diventano attori di un sapiente gioco di luci e ombre, riflessi e colori, per un'esperienza multisensoriale tra sogno e realtà; il legno viene lavorato, modellato ed adattato da esperti artigiani, dando vita ad opere uniche, ogni volta caratterizzate da una mutevole, inaspettata, sensoriale, rilassante energia espressiva e comunicativa in cui l'incontro tra luce e legno ne rileva l'anima nascosta e la sua natura tridimensionale e segreta.

Il legno, diversamente da tutto ciò che non è materia viva, basa la sua identità sulle imperfezioni, che diventano punti di forza, sempre unici e diversi, differenti persino da sé stessi proprio per la sua naturale dinamicità e vibrante vitalità; Brightwood® ne esalta la materica muta sinfonia del legno, raccontandone ogni volta una storia antica ma sempre nuova, fatta di colori e sfumature, esaltando il tridimensionale fascino misterioso, unico ed inaspettato di ogni essenza.





Each of Brightwood®'s creations celebrates nature with all its colors, opening up to contaminations with worlds that are closely related, such as interior design and furniture, but also those more distant of art and fashion.

Alongside the pieces in the collection, the Brightwood® creative team listens to the needs of clients to also create furniture and customized decorative elements.

Brightwood® offers a wide selection of woods that stand out for their unique colors, veining and patterning, enhancing their splendor and innate beauty thanks to the skillful combination of craftsmanship and technological innovation. With Brightwood®, wood expresses a host of sensations that arouse in us memories of the cognitive experience that has been present for millions of years.

The ancestral bond between humans and wood is thus constantly renewed by the multiple sensory stimuli that wood offers every single day and which involve each of the five senses, both directly and indirectly.

Ogni realizzazione firmata Brightwood® celebra, con le sue cromie, la natura, aprendosi a contaminazioni con mondi che non sono solamente i più vicini, come quello dell'interior design e dell'arredo, ma anche quelli dell'arte e della moda.

A fianco dei pezzi in collezione, il team creativo Brightwood®, ascoltando le esigenze del cliente, realizza anche mobili ed elementi decorativi su misura.

Brightwood® propone un'ampia selezione di essenze lignee che si contraddistinguono per colori, venature e motivi unici, esaltandone lo splendore e l'innata bellezza grazie al saggio connubio di maestria artigianale e innovazione tecnologica: il legno esprime con Brightwood® un bagaglio di sensazioni che suscitano in noi la reminiscenza dell'esperienza conoscitiva che va avanti da milioni di anni.

Il legame ancestrale tra uomo e legno viene così costantemente rinnovato dalle molteplici stimolazioni sensoriali che il legno offre ogni giorno e che coinvolgono, direttamente o indirettamente, tutti i cinque sensi.



NOTAS:

BRIGHTWOOD®

Wood and SIGHT

Il legno e la VISTA



The visual emotion is immediate, the veining and the innumerable shades of color are in fact a striking example of what we usually call a

MIRACLE OF NATURE

It is said that the human eye is able to distinguish as many as ten million different shades, and so it is easy to understand how the presence of wood, enhanced by the innumerable shades of the Brightwood® effect, can have a decisive and positive influence on our state of mind and contribute to the overall harmony of the home.

Immediata è l'emozione di tipo visivo, le venature e le innumerevoli tonalità di colore sono infatti un esempio lampante di quel che siamo soliti definire

MIRACOLO DELLA NATURA

Si dice che l'occhio umano sia in grado di distinguere ben dieci milioni di tonalità diverse, ed è facile quindi comprendere quanto la presenza del legno, esaltato dall'effetto Brightwood® nelle sue innumerevoli tonalità, sia da considerarsi contributo determinante per il nostro stato d'animo e per una più generale armonia della casa.

The heat felt when touching the wood reminds us of that sensation of well-being when the sun caresses the skin or that of a warm fire, feelings that no other type of material is able to arouse.

Nowadays, we often enter places that are devoid of any detail, driven by an increasingly extreme minimalism in the constant search for the perfection of neutrality. Wood makes the house come back to life, without disturbing the coveted essential line of the decor.

Il calore che emana il legno al tocco ci rimanda al benessere del sole sulla pelle, a quello del camino acceso, percezioni impossibili da avere con qualsiasi altro tipo di materiale.

Oggi come oggi è frequente imbattersi in ambienti privi di dettagli, che virano sempre più verso il minimalismo estremo alla costante ricerca della perfezione della neutralità: il legno fa sì che la casa riacquisti vita, senza turbare l'agognata linea essenziale d'arredo.

BRIGHTWOOD®

Wood and TOUCH

Il legno e il TATTO



BRIGHTWOOD®

Wood and SOUND

Il legno e l'UDITO

What do we normally and instinctively do
when faced with wood surfaces?

KNOCK!

We knock, we strike the wood with the
knuckles to make it resonate and feel its
unique sound and unmistakable vibrations.

Qual è poi il gesto naturale che siamo
soliti fare in presenza di superfici in legno?

BUSSARE!

Bussare, colpire il legno con le nocche delle
dita per farlo vibrare e sentire il suo suono
unico e le sue vibrazioni inconfondibili.

Wood is also savored for the characteristic fragrances that stimulate our sense of smell.

The wide variety of woods translates into a very rich and complex range of scents, but with one thing in common: a dry, seductive smell, which tastes of life, of nature, of home.

This aromatic experience reminds us of that of flavor and taste, evoking certain tannic flavors of fine aged wines.

Il legno si lascia apprezzare anche per le caratteristiche fragranze che sollecitano il nostro olfatto.

La grande varietà di essenze rende il ventaglio olfattivo molto ricco e complesso, anche se una nota rimane comune: un odore secco, seducente, che sa di vita, di natura, di casa.

L'esperienza olfattiva ci rimanda, infine, a quella del sapore, del gusto, rievocando certi sapori tanninici di preziosi vini invecchiati.

BRIGHTWOOD®

Wood, SMELL and TASTE

Il legno, l'OLFATTO e il GUSTO

BRIGHTWOOD®

Teseo
Ippolita
Beatrice
Enea

2023 COLLECTION

DESIGN BY



AMARANTO
interior

Brightwood® OFF

BEATRICE Sideboard \ Madia
150x60xh88 cm
Oak W104, Ash Brightwood® BW108, Bronze

IPPOLITA Armchair \ Poltrona
75x100xh69cm
Leather AL 108, Erable Friséè Brightwood® BW106, Bronze

Boiserie
Custom \ Su misura
Olive Ash Brightwood® BW109





Brightwood® ON 100%

BEATRICE Sideboard \ Madia
150x60xh88 cm
Oak W104, Ash Brightwood® BW108, Bronze

IPPOLITA Armchair \ Poltrona
75x100xh69cm
Leather AL 108, Erable Friséè Brightwood® BW106, Bronze

Boiserie
Custom \ Su misura
Olive Ash Brightwood® BW109









The new collection enhances the power of Brightwood®, exploits its dynamics, its muted symphony, its materiality. The pieces light up in the dark and attract the observer, inviting him to perceive wood in an unexpected, sensorial, relaxing way thanks to the energy emanating from its unexpected shapes and veins.

Surprising planes of light and soft decorations light up in the darkness of a hidden, undiscovered, never-before encountered forest.

La nuova collezione esalta la potenza di Brightwood®, ne sfrutta la sua dinamica, la sua sinfonia muta, la sua matericità.

I pezzi si accendono nel buio e attraggono l'osservatore invitandolo a percepire il legno in modo inaspettato, sensoriale, rilassante grazie all'energia emanata dalle sue forme e vene inaspettate.

Sorprendenti piani di luci e morbide decorazioni si accendono nel buio di una foresta nascosa, scoperta, mai incontrata prima.

Brightwood® OFF

TESEO Dining table \ Tavolo da pranzo
ø220xh75 cm

Walnut W103, Olive wood Brightwood® BW112, Crome

This is the spirit: a collection of very few, iconic, sculptural pieces, born from the intuition of a wood professional, who wanted to unveil the true soul of wood, its depth never shown, the result of a long research and a strong passion, since childhood, inspired by the desire to discover in the depths of wood what is hidden.

This thought is described and shared and becomes, thanks to the creativity of the Amaranto Interiors designers, a tangible collection, unique in its form and surprising in its product.

Questo è lo spirito della nuova collezione: una collezione di pochissimi pezzi, iconici, scultorei, nati dall'intuizione di un professionista del legno, che del legno ha voluto svelarne la vera anima, la sua profondità mai mostrata, frutto di una lunga ricerca e di una forte passione, sin da bambino, ispirata dalla voglia di scoprire nella profondità del legno che cosa è celato.

Questo pensiero viene descritto e condiviso e diventa, grazie alla creatività dei designers Amaranto Interiors, una collezione tangibile, unica nelle sue forme e sorprendente nel prodotto.

Brightwood® ON 100%

TESEO Dining table \ Tavolo da pranzo
 ø220xh75 cm
 Walnut W103, Olive wood Brightwood® BW112, Crome







Brightwood® ON 100%

TESEO Dining table \ Tavolo da pranzo
ø220xh75 cm
Walnut W103, Olive wood Brightwood® BW112, Crome







Brightwood® ON 100%

TESEO Dining table \ Tavolo da pranzo
180x110xh75 cm

Oak W104, Ash Brightwood® BW108, Bronze

BEATRICE Sideboard \ Madia
150x60xh88 cm

Oak W104, Maple Friséè Brightwood® BW101, Bronze



BRIGHTWOOD®



Brightwood® ON 100%

TESEO Dining table \ Tavolo da pranzo
ø220xh75 cm

Walnut W103, Zebrano Brightwood® BW113, Bronze

BEATRICE Bar cabinet \ Vetrina
120x50xh160 cm

Oak W104, Olive Ash Brightwood® BW109, Gun Metal



Brightwood® ON 100%

IPPOLITA Armchair \ Poltrona

75x100xh69 cm

Leather AL 104, Erable Brightwood® BW106, Bronze

IPPOLITA Chaise Longue

75x153xh69 cm

Leather AL 104, Erable Brightwood® BW106, Bronze

TESEO Dining Table \ Tavolo da pranzo

ø220xh75 cm

Walnut W103, Zebrano Brightwood® BW113, Bronze

ENEA Boiserie

120xh250 cm

Oak W104, Zebrano Brightwood BW113, Leather AL104, Bronze

Stair \ Scala

Custom \ Su misura

Ash Brightwood® BW108, Bronze



BRIGHTWOOD®

Teseo
Ippolita
Beatrice
Enea

TECHNICAL INFORMATION

DESIGN BY



AMARANTO
interior

TESEO

DINING TABLE \ TAVOLO DA PRANZO

A top with shaped profiles supported by four sculptural legs featuring Brightwood® on one of their faces.
This is the Teseo table. The particularity of the leg is enriched with details
and makes the table unique and sculptural.

Un piano dai profili sagomati sorretto da quattro gambe scultoree caratterizzate da Brightwood® in una delle facce.
Questo è il Tavolo Teseo. La particolarità della gamba è arricchita da dettagli
e rende il tavolo unico e scultoreo.

180x110xh75 cm - 220x110xh75 cm - 250x110xh75 cm

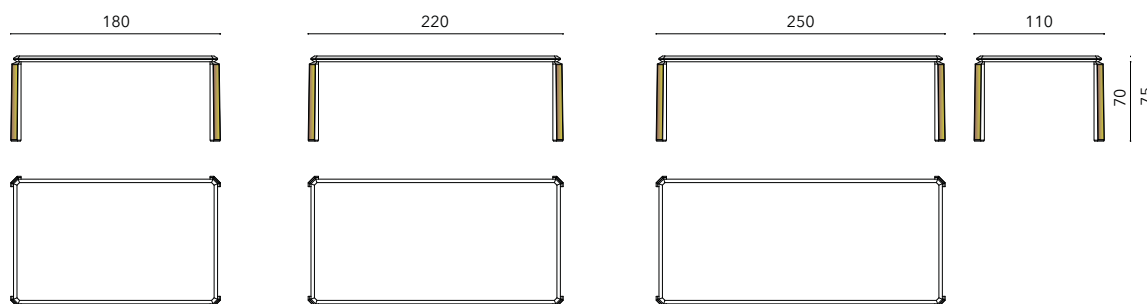

LED 4.000° K consumption 50 Watts battery hours of power 1.800 hours at 800 lumen meter,
dimnable and remote control, LED life 200.000 hours, Driver life 80.000 hours

LED 4.000° K consumo 50 Watts batteria con autonomia di 1.800 ore a 800 lumen metro,
dimmerabile e telecomando, durata LED 200.000 ore, durata del Driver 80.000 ore

BRIGHTWOOD®

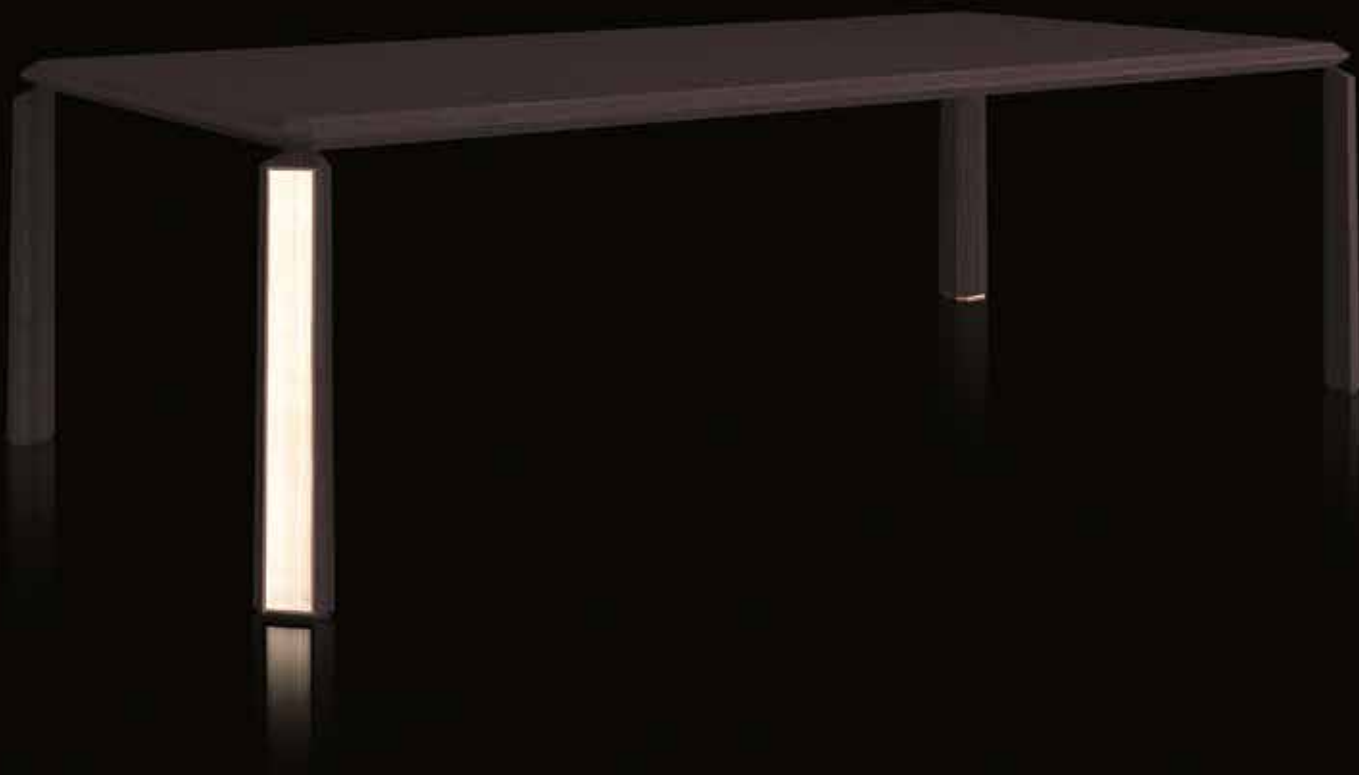

Brightwood® ON 100%

220x110xh75 cm

Oak W104, Ash Brightwood® BW108, Bronze

BRIGHTWOOD®



Brightwood® ON 100%

ø220xh75 cm

Walnut W103, Olive wood Brightwood® BW112, Crome

TESEO

DINING TABLE \ TAVOLO DA PRANZO

The sinuosity of the circular forms is broken up by illuminated tops that seem to cut through a trunk and reveal the soul within. The legs of the circular version of the Teseo table enhance the power of Brightwood® and make the piece unique and distinctive.

Model 220 is available with Lazy Susan.

La sinuosità delle forme circolari è spezzata da piani illuminati che sembrano tagliare un tronco e svelarne l'anima al suo interno. Le gambe del tavolo Teseo in versione circolare esaltano la potenza del legno Brightwood® e rendono il pezzo unico e caratteristico.

Il modello 220 è disponibile con Lazy Susan.

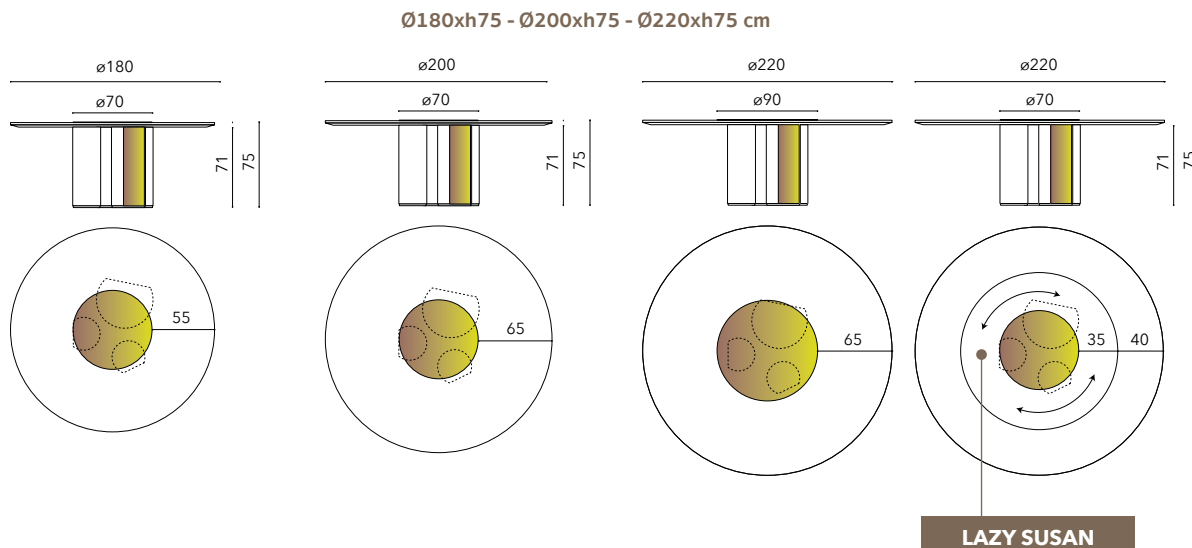

LED 4.000° K consumption 50 Watts battery hours of power 1.800 hours at 800 lumen meter, dimmable with remote control, LED life 200.000 hours, Driver life 80.000 hours

TopLED 4.000° K consumo 50 Watts batteria con autonomia di 1.800 ore a 800 lumen metro, dimmerabile e telecomando, durata LED 200.000 ore, durata del Driver 80.000 ore

BRIGHTWOOD®



Brightwood® OFF

ø220xh75 cm

Walnut W103, Olive wood Brightwood® BW112, Crome

Brightwood

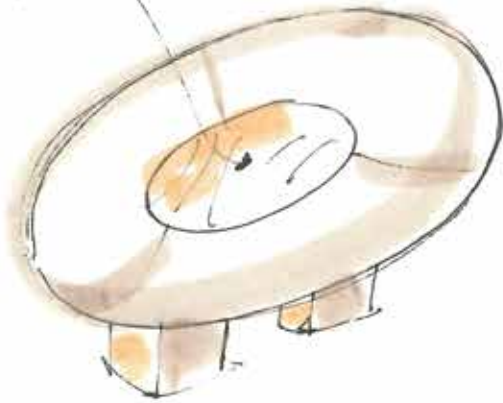

Brightwood



legno
naturale nat.

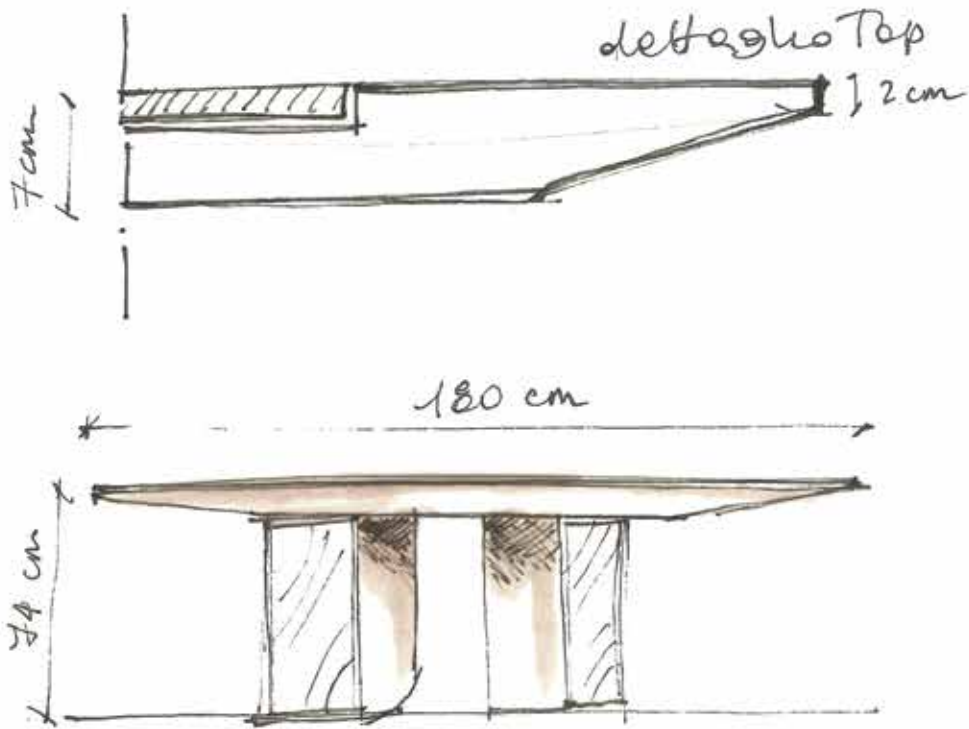

φ 180 mm

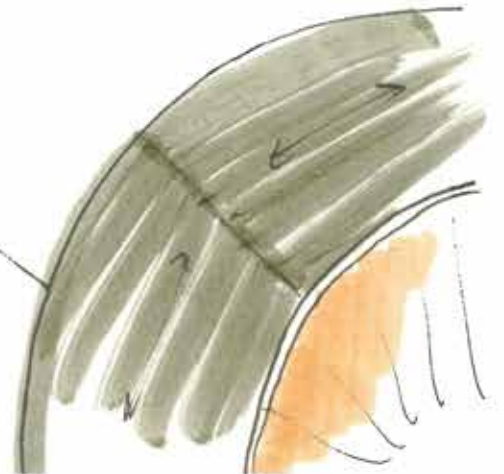

IPPOLITA

ARMCHAIR \ POLTRONA
CHAISE LONGUE

A compact, sinuous shape, characterised by the upholstered cushion cover that follows the curve.
The Ippolita armchair and chaise longue have sides in Brighwood® and become a decorative and luminous elements in any environment in which they are placed.

Una forma compatta, sinuosa, caratterizzata dal rivestimento del cuscino imbottito che ne segue la curva.
La poltrona e la chaise longue Ippolita presentano i lati in Brighwood® e diventano elemento decorativo e luminoso in ogni ambiente in cui sono inserite.

100x75xh69 cm
153x75xh69 cm

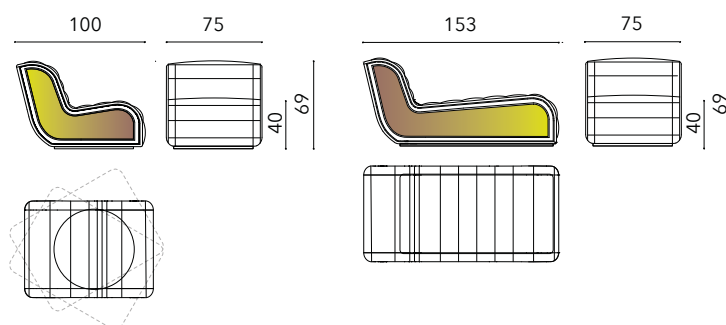

LED 4.000° K low consumption 50 Watts battery hours of power 1.800 hours at 800 lumen meter,
dimnable with remote control LED life 200.000 hours, Driver life 80.000 hours.

LED 4.000° K bassi consumi da 50 Watts autonomia batteria da 1.800 ore a 800 lumen metro,
dimmerabile con telecomando durata LED 200.000 ore, Driver durata 80.000 ore.

BRIGHTWOOD®



Brightwood® ON 100%

100x75xh69 cm

Leather AL 104, Erable Brightwood® BW106, Bronze



Brightwood® ON 100%

153x75xh69 cm

Leather AL 104, Erable Brightwood® BW106, Bronze



*Bate
girevole*



luminosa



ergonomic



BEATRICE

SIDEBOARD \ MADIA

The central slit, which conceals the Brightwood® lighting, makes the Beatrice sideboard a unique piece.

La fessura centrale, che cela l'illuminazione del Brightwood®, rende la madia Beatrice un pezzo unico nella sua forma.

150x60xh88 cm

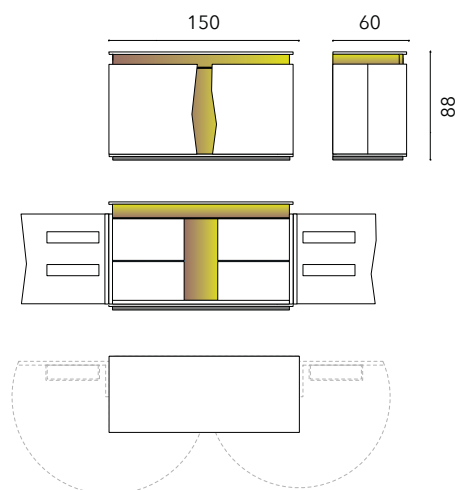

LED 4000° K low consumption 50 Watts battery hours of power 1.800 hours at 800 lumen meter, dimmable and remote control LED life 200.000 hours, Driver life 80.000 hours.

LED 4000° K bassi consumi da 50 Watts autonomia batteria da 1.800 ore a 800 lumen metro, dimmerabile e telecomando durata LED 200.000 ore, Driver durata 80.000 ore.

BRIGHTWOOD®

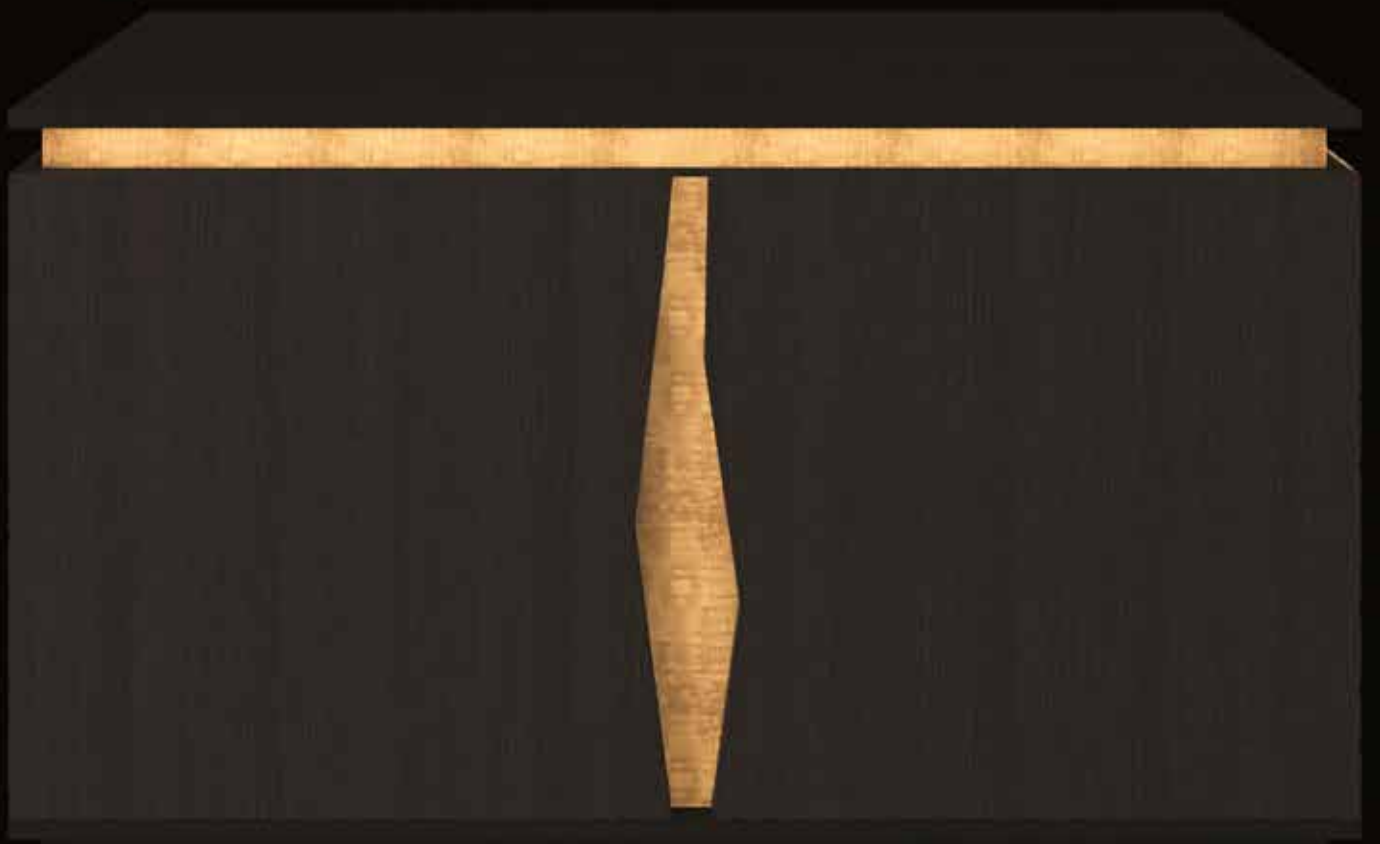

Brightwood® ON 100%

150x60x88 cm

Oak W104, Maple Frisé Brightwood® BW101, Bronze



Brightwood® OFF

150x60xh88 cm

Oak W104, Maple Frisè Brightwood® BW101, Bronze

BRIGHTWOOD®



Brightwood® OFF

120x50xh160 cm

Oak W104, Olive Ash Brightwood® BW109, Gun Metal



Brightwood® ON 100%

120x50xh160 cm

Oak W104, Olive Ash Brightwood® BW109, Gun Metal

BEATRICE

BAR CABINET \ VETRINA

The power of Brightwood® is the protagonist in the tall Beatrice sideboard. The central slit widens, allowing an important, fully-lit Brightwood® back panel to shine through the glass, enhancing its sculpturality and importance. Beatrice sideboard becomes the protagonist in the environment in which it is inserted.

La potenza del Brightwood® è protagonista nella madia alta Beatrice, la fessura centrale si allarga, lasciando trasparire dal vetro un importante schienale completamente illuminato in Brightwood® che ne esalta la scultoreità e l'importanza. Madia Beatrice diventa protagonista nell'ambiente in cui è inserita.

120x50xh160 cm

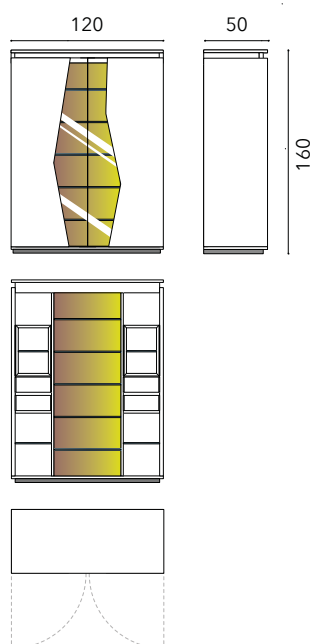

LED 4.000° K low consumption 50 Watts battery hours of power 1.800 hours at 800 lumen meter, dimmable and remote control, LED life 200.000 hours, Driver life 80.000 hours.

LED 4.000° K bassi consumi da 50 Watts autonomia batteria 1.800 ore a 800 lumen metro, dimmerabile e telecomando, durata del LED 200.000 ore, Driver durata 80.000 ore.

ENE A

BOISERIE

Brightwood® becomes a discreet protagonist of the space in the Enea boiserie.
 The geometric design is a continuous alternation
 of Brightwood® natural wood panels and panels covered in leather or nabuck.
 Its simple, linear design is infinitely repeatable,
 creating new combinations of Brightwood® light on the wall.

Brightwood® diventa discreto protagonista dello spazio nella boiserie Enea.
 Il disegno geometrico è una continua alternanza di pannelli
 in essenza naturale Brightwood® e pannelli rivestiti in pelle o nabuck.
 Il suo design semplice e lineare è ripetibile all'infinito,
 creando sempre nuove combinazioni di luce Brightwood® a parete.

120x250 cm

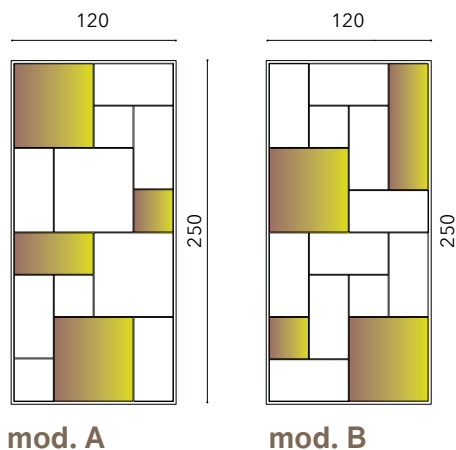

LED 4000° K low consumption 50 Watts battery hours of power 1.800 hours at 800 lumen meter,
 dimmable and remote control LED life 200.000 hours, Driver life 50000 hours.

LED 4000° K bassi consumi da 50 Watts autonomia batteria da 1.800 ore a 800 lumen metro,
 dimmerabile e telecomando durata LED 200.000 ore, Driver durata 50000 ore.



Brightwood® ON 100%

120xh250 cm

Oak W104, Zebrano Brightwood BW113, Leather AL104

The images of the different woods are purely representational.
Being a product of nature, each plank of wood has its own characteristics.

The images are only intended to represent the range of finishes available,
and color variations between the printed image and the real product are possible.

All Brightwood® products are individually powered
with rechargeable 12/24-volt battery power
and, on request, also directly with 220 volts and 12/24 volt drivers.

After continuous use of up to 15 hours,
the battery should not be used for at least 4 hours.

All Brightwood® products are dimmable,
in the finishes sample are represented only 3 steps: 0 / 50 / 100%.

The most faithful reproduction of the Brightwood® effect can be seen with the videos
on the website - www.brightwood.it - which we invite you to visit.



Le immagini dei legni sono solo rappresentative:
in quanto prodotto della natura, ogni lastra di legno ha caratteristiche proprie.

Le immagini hanno solo lo scopo di rappresentare la gamma di finiture disponibili.
Sono possibili variazioni cromatiche tra stampa e campione reale.

Tutti i prodotti Brightwood® sono alimentati singolarmente
con alimentazione a batteria da 12/24 volt ricaricabili
e, su richiesta, anche direttamente a 220 volt e driver 12/24 volt.

Dopo un utilizzo continuativo di massimo 15 ore,
la batteria non deve essere utilizzata per minimo 4 ore.

Tutti i prodotti Brightwood® sono dimmerabili,
nel campionario finiture sono rappresentati solo 3 step: 0 / 50 / 100%.

La più fedele riproduzione dell'effetto Brightwood® è visibile con i video
presenti sul sito web - www.brightwood.it - che vi invitiamo a visitare.

BRIGHTWOOD®

FINISHINGS

The BRIGHTWOOD® WOOD FINISHINGS represented below are available with Brightwood® effect and, for the structural parts of the collection pieces, also without Brightwood® effect.

Due to constraints of paper communication, only 3 lighting steps are depicted below:

OFF - ON 50% - ON 100%.

All products are dimmable.

Le FINITURE LEGNI BRIGHTWOOD® di seguito rappresentate sono disponibili con effetto Brightwood® e, per le parti strutturali dei pezzi a collezione, anche senza effetto Brightwood®.

Per vincoli legati alla comunicazione su carta sono di seguito rappresentati solo 3 step dell'illuminazione:

OFF - ON 50% - ON 100%.

Tutti i prodotti sono dimmerabili.

OFF

ON 50%

ON 100%



C

BW101

MAPLE FRISEÈ \ ACERO FRISEÈ

OFF

ON 50%

ON 100%



C

BW102

CALEIDOLEGNO

OFF

ON 50%

ON 100%



C

BW103
CALEIDOLEGNO

OFF

ON 50%

ON 100%



C

BW104
CALEIDOLEGNO

OFF

ON 50%

ON 100%



A

BW105
CHERRY WOOD \ CILIEGIO

OFF

ON 50%

ON 100%



B

BW106
ERABLE FRISEÈ

OFF

ON 50%

ON 100%



A

BW107
CRUDE BEECH \ FAGGIO CRUDO

OFF

ON 50%

ON 100%

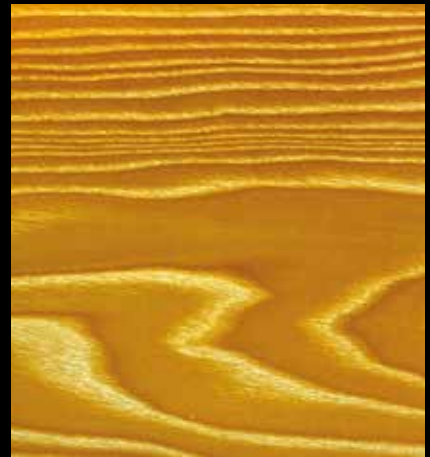

A

BW108
ASH \ FRASSINO

OFF

ON 50%

ON 100%



A

BW109
OLIVE ASH \ FRASSINO OLIVATO

OFF

ON 50%

ON 100%



B

BW110
NEW WOOD BOLIVAR

OFF

ON 50%

ON 100%

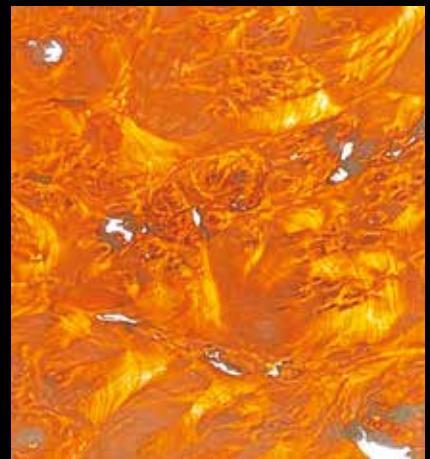
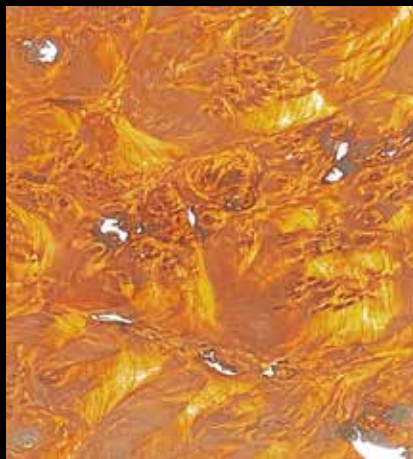

A

BW111
ROOT MAPLES \ RADICA

OFF

ON 50%

ON 100%



A

BW112
OLIVE WOOD \ ULIVO

OFF

ON 50%

ON 100%



C

BW113
ZEBRANO

OFF

ON 50%

ON 100%



C

BW114
ABETE

The WOOD FINISHES represented below are available only for the structural parts of the collection pieces without Brightwood® effect.

Le FINITURE LEGNI di seguito rappresentate sono disponibili solo per le parti strutturali dei pezzi a collezione senza effetto Brightwood®.



B

W101
EBONY \ EBANO



C

W102
NEW WOOD



B

W103
WALNUT \ NOCE



B

W104
OAK \ ROVERE



C

W105
ZEBRANO DARK \ SCURO

The CARVED FINISHINGS represented below are available only for the doors of BEATRICE sideboard and bar cabinet. They are to be quoted as an extra price.

Le FINITURE SCOLPITE di seguito rappresentate sono disponibili solo per le ante della madia e vetrina BEATRICE. Sono da quotare come extra price.



CARVED OAK\
ROVERE SCOLPITO



CARVED WALNUT\
NOCE SCOLPITO

Three METAL FINISHINGS are available to give the possibility of coordinating the chosen wood with the shade that best suits the customer's taste.

Sono disponibili tre FINITURE METALLICHE per dare la possibilità di coordinare il legno scelto con la sfumatura che meglio si adatta al gusto del cliente.



M101
BRONZE \ BRONZO



M102
GUN METAL \ CANNA di FUCILE



M103
CROME \ CROMO



A **AL101**



A **AL102**



A **AL103**



A **AL104**



A **AL105**



A **AL106**



A **AL107**

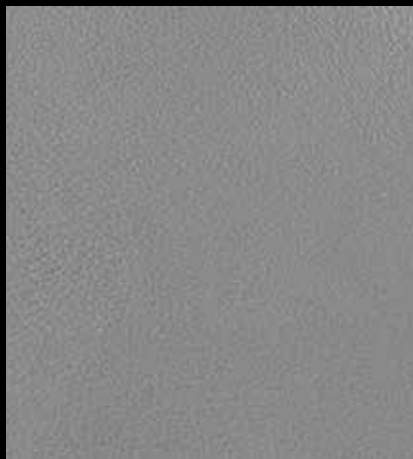

A **AL108**



B **BL101**



B **BL102**



B **BL103**



A **BL104**

BRIGHTWOOD® Srl

Via Carducci 6
20090 Vimodrone (MI) - ITALY
Tel. +39 02 67179092
info@brightwood.it

brightwood.it

Brightwood® is a registered industrial design.

Brightwood® is a registered logo.

Brightwood® Srl reserves the right to make improvements, at any time and without notice,
to the products presented in this catalogue.

Brightwood® è un disegno industriale registrato.

Brightwood® è un marchio registrato.

Brightwood® Srl si riserva il diritto di apportare modifiche migliorative,
in qualsiasi momento e senza preavviso, ai prodotti presentati in questo catalogo.

ART DIRECTION & STYLING AMARANTOINTERIOR.COM

GRAPHIC DESIGN MARTABUCCELLA.COM

PHOTOS SHO3D.IT